

TSUBAKI EMERSON BACK STOP CAM CLUTCH BS-HS series

High Speed and High Performance

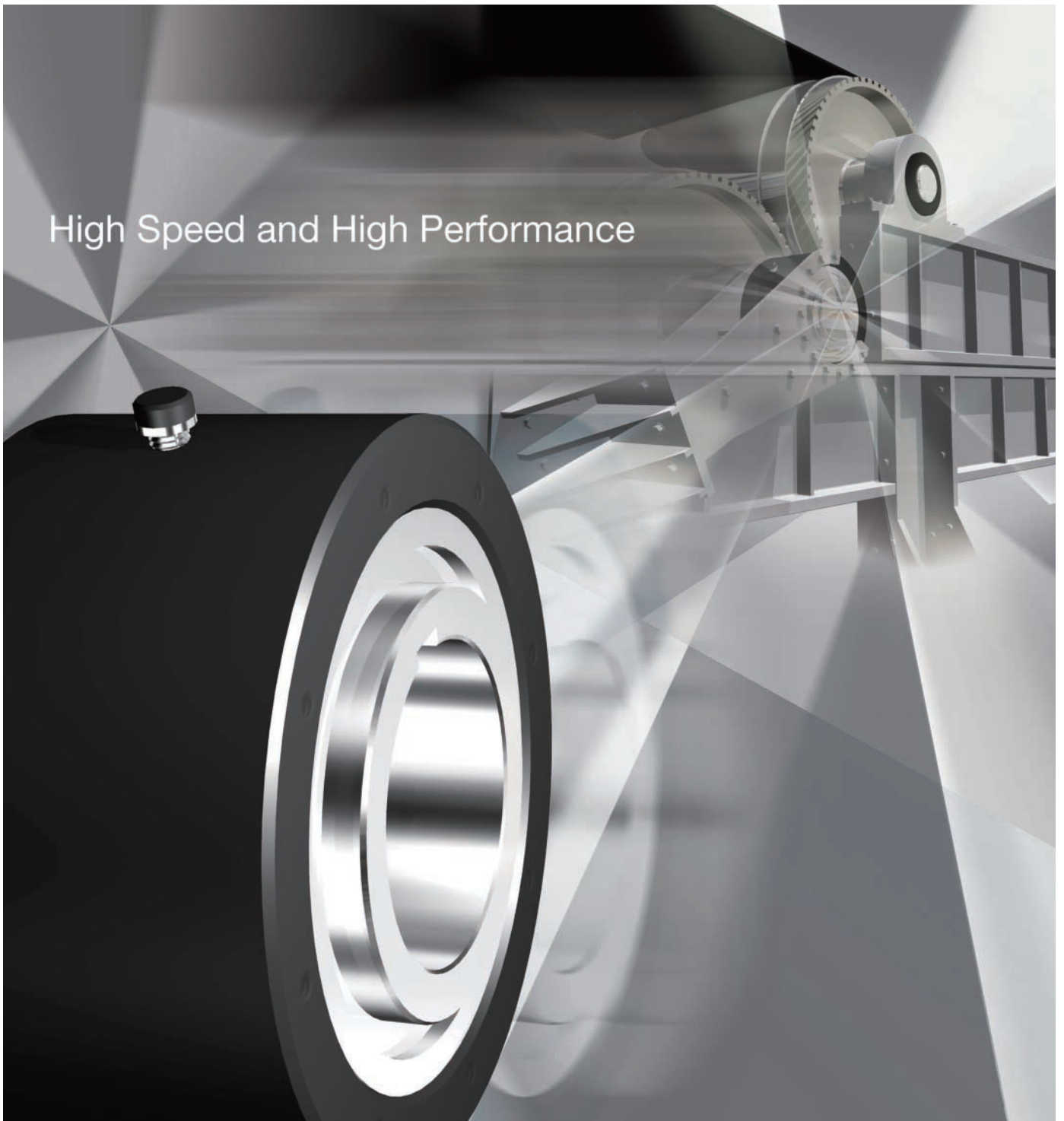

Tsubaki-Emerson Back

New BS-HS series offer many advantages

High Speed, High performance, High Reliability

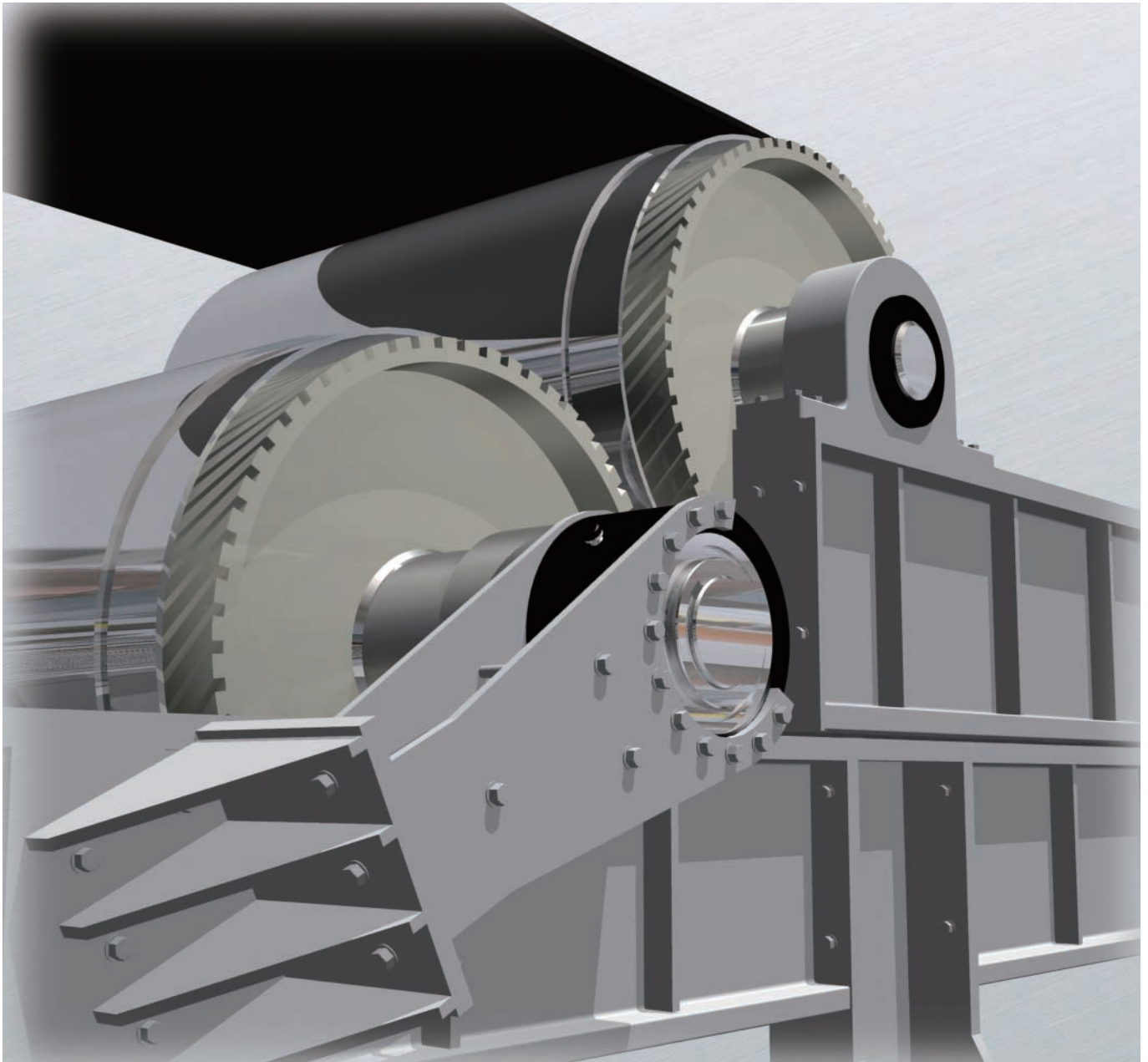

Typical applications

- Belt conveyors for mining, mineral, metals, timber, pulp, wood chip, power stations etc. –
- Bucket elevators for cement, grain etc.
- Large drift conveyors
- Screw pumps

Stop Cam Clutches

not found in conventional models

Design Features

Higher torque/speed capacity

New camcage and bearing supported design will provide higher torque/speed capacity compared with conventional models. This can often permit use of a smaller clutch...providing further cost savings.

In addition, we are providing the double camcage model with higher torque capacity.

Please contact Tsubaki Emerson.

Anti-rollover cam design

Precise formed cams having unique design shape are "anti rollover type", which assure superior durability against heavy shock load in back stopping.

Longer clutch life

Clutch component parts are made of selected alloy steel and effectively heat-treated. This provides long wear resistance and long life performance.

Low maintenance

Only minimum maintenance for lubricant is required, since special heat-resistant grease is packed in. This makes maintenance easier and remarkably reduces maintenance cost.

Dust-proof construction

Combination double lip oil seal and dust protective plate keep grease in and dust out.

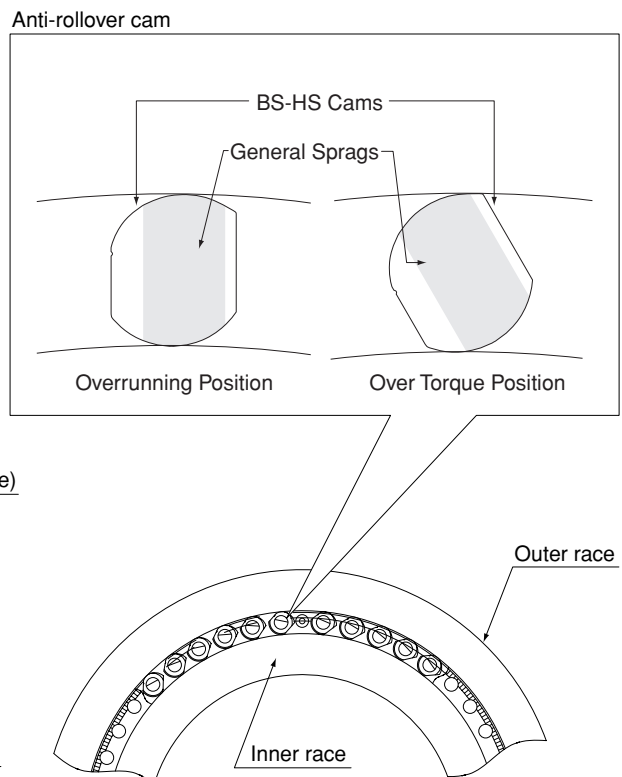
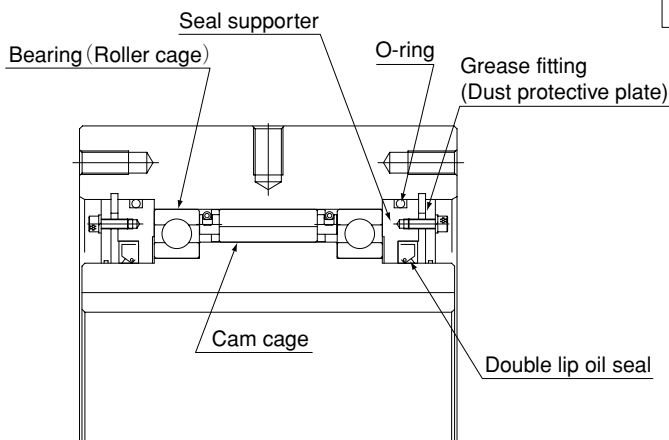

BS-HS SERIES CAM CLUTCH

■ Models BS160HS to BS450HS

BS160HS to BS270

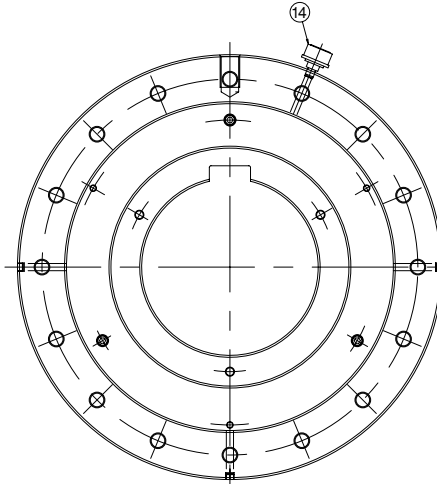
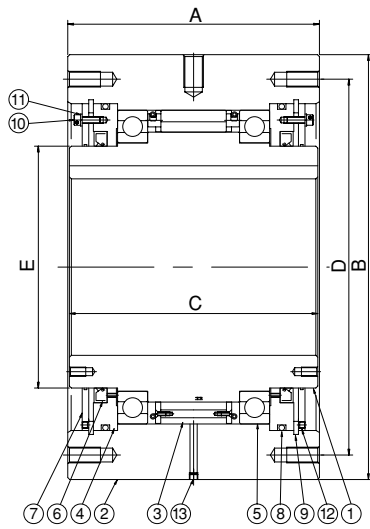

- ① Inner race
- ② Outer race
- ③ Cam cage
- ④ Seal supporter
- ⑤ Bearing
- ⑥ Oil seal
- ⑦ Grease fitting
- ⑧ O-ring
- ⑨ Snap ring
- ⑩ Socket bolt
- ⑪ Seal washer
- ⑫ Set screw
- ⑬ Socket plug
- ⑭ Air breather

BS300HS to BS350HS

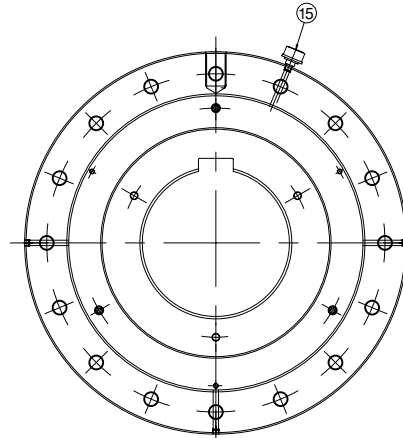
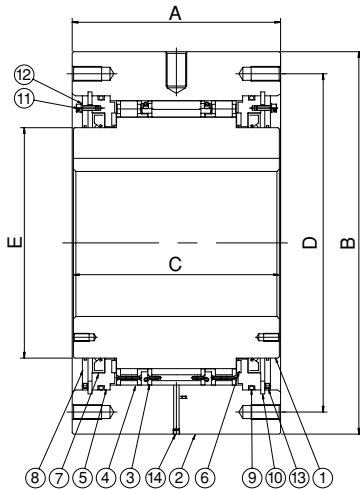

- ① Inner race
- ② Outer race
- ③ Cam cage
- ④ Roller cage
- ⑤ Seal supporter
- ⑥ Thrust bearing
- ⑦ Oil seal
- ⑧ Grease fitting
- ⑨ O-ring
- ⑩ Snap ring
- ⑪ Socket bolt
- ⑫ Seal washer
- ⑬ Set screw
- ⑭ Socket plug
- ⑮ Air breather

BS425HS to BS450HS

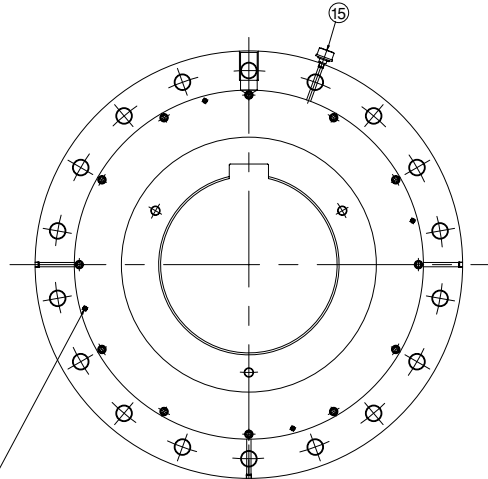
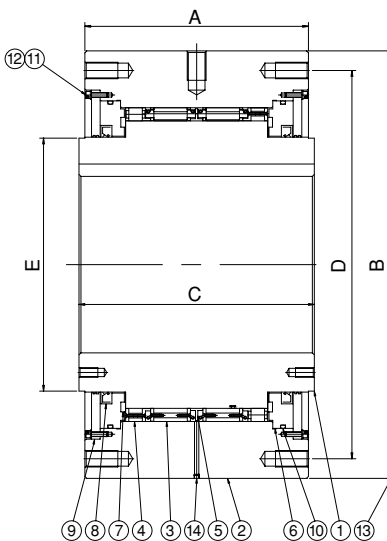

- ① Inner race
- ② Outer race
- ③ Cam cage
- ④ Roller cage
- ⑤ Spacer ring
- ⑥ Seal supporter
- ⑦ Thrust bearing
- ⑧ Oil seal
- ⑨ Grease fitting
- ⑩ O-ring
- ⑪ Socket bolt
- ⑫ Seal washer
- ⑬ Set screw
- ⑭ Socket plug
- ⑮ Air breather

Dimensions and Capacities

Model	Max. Torque N-m{kgf-m}	Bore Dia. Range (mm)	Max. Overrunning Speed Inner Race (r/min.)	Nominal Overrunning Drag Torque N-m{kgf-m}	A	C	B	E	PCD D	S	H-M No. of Tapped Holes XSizeXPitch	Q'ty of Grease (kg)	Weight (kg)
BS160HS	39,200{4,000}	100~160	350	34.3{3.5}	180	175	360	220	315	40	10×M20×P2.5	0.41	120
BS200HS	61,700{6,300}	100~200	250	44.1{4.5}	205	200	430	260	380	40	8×M22×P2.5	0.55	200
BS220HS	102,000{10,400}	150~220	200	73.5{7.5}	330	325	500	290	420	40	16×M20×P2.5	1.5	390
BS250HS	147,000{15,000}	175~250	170	93.1{9.5}	370	365	600	330	530	50	16×M24×P3.0	3.7	760
BS270HS	204,000{20,800}	200~270	160	98.0{10}	385	380	650	370	575	50	16×M24×P3.0	4.4	850
BS300HS	294,000{30,000}	230~300	150	108{11}	425	420	780	470	690	60	16×M30×P3.5	6.7	1,400
BS350HS	392,000{40,000}	250~350	110	157{16}	440	480	930	535	815	70	16×M36×P4.0	7.7	2,300
BS425HS	735,000{75,000}	325~425	85	216{22}	570	580	1,030	635	940	70	18×M36×P4.0	10	3,300
BS450HS	980,000{100,000}	350~450	80	245{25}	570	600	1,090	645	990	80	18×M42×P4.5	11	3,700

Installation and Usage

- For prevention of rotation in the reverse direction on conveyors or pumps.
- Lubrication method and dust prevention features:
Change the grease once every 6 months~12months.
Combination double lip oil seal and dust protective plate keep grease in and dust out.
- Before installation, verify that the direction of rotation of the inner race of the BS-HS Cam Clutch (shown by the arrow on the inner race) is the same as the direction of rotation of the conveyor.
- Securely install the torque arm to the BS-HS Cam Clutch using bolts of strength 10.9 or higher. Make sure that the contact between the surface of the torque arm and the side of the outer race is level and free of dust.
- Recommended shaft tolerance is h7 or h8.
- When inserting the BS-HS Cam Clutch on the shaft, apply pressure only on the inner race. Do not tap the inner race directly with a hammer or exert any force upon the outer race, dust seal, or dust plate.
- Always use a parallel key for installation onto the shaft and then fix the BS-HS Cam Clutch to the shaft with the end plate. Never use a tapered key.
- When installing cam clutches, place one of the four oil plugs in the direct bottom location. This will allow for easy drainage of the grease for cleaning.
- While the shaft is rotating, the end of the torque arm will swing to some extent in the direction of rotation. Support the torque arm end only in the direction of rotation, but be sure to allow it a certain amount of free swing. If the torque arm end is fixed securely (see installation diagram), the inside of the clutch becomes twisted, and this can result in damage to the components.
- For models BS160HS to BS200HS, a single torque arm on one side is sufficient, but for models BS220HS to BS450HS, use two torque arms, one on each side. Install the torque arms evenly so the force is transmitted through the center of the clutch.
- Torque arms for the BS Cam Clutch are options. Please inquiry to Tsubaki Emerson the dimension of torque arms.
- See "Lubrication and Maintenance" on page 6.

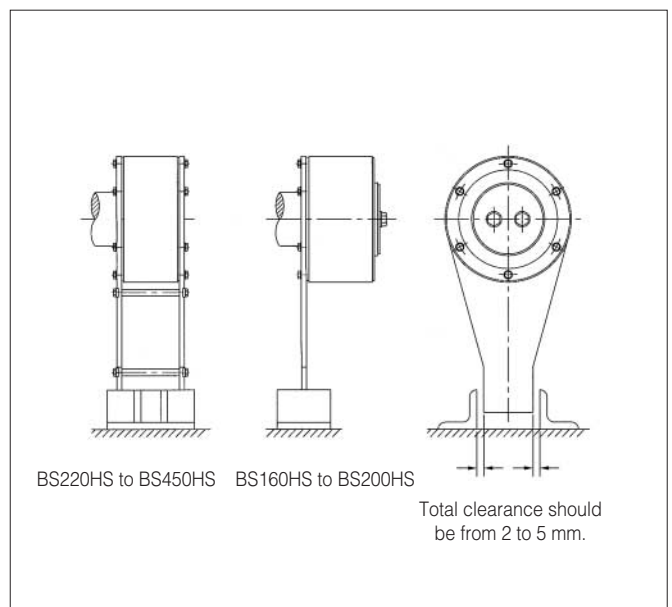
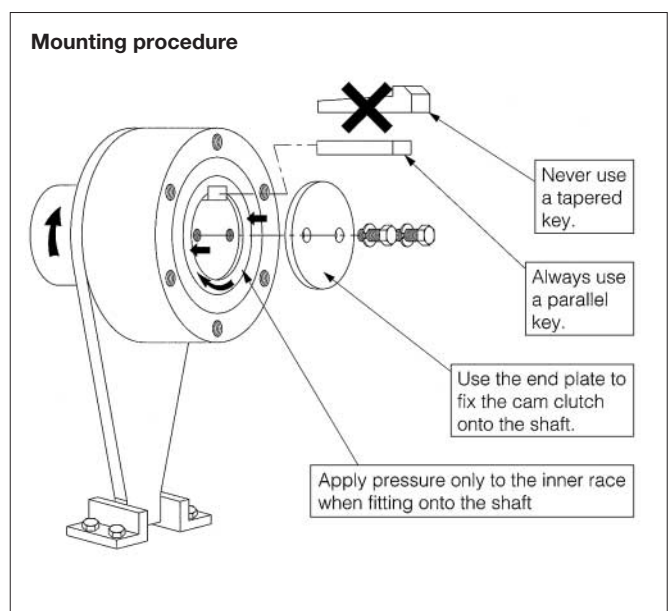

■ INFORMATION FOR SELECTION

For Belt Conveyors

Selection Procedure:

(1) Calculate the power to move an empty belt and idlers: (P_1)

$$P_1 = 0.06 \times f \times W \times V \times \frac{\ell + \ell_0}{367} \text{ (kW)}$$

(2) Calculate the power to move a loaded belt horizontally: (P_2)

$$P_2 = f \times Q_t \times \frac{\ell + \ell_0}{367} \text{ (kW)}$$

(3) Calculate the power to move the load vertically: (P_3)

$$P_3 = \frac{h \times Q_t}{367} \text{ (kW)}$$

(4) Calculate the back stop power: (P_r)

$$P_r = P_3 - 0.7(P_1 + P_2) \text{ (kW)}$$

(5) Calculate the back stop torque: (T)

$$T = \frac{9550 \times P_r}{N} \times SF \text{ (N·m)}$$

(6) Select the proper clutch which satisfies the calculated backstop torque.

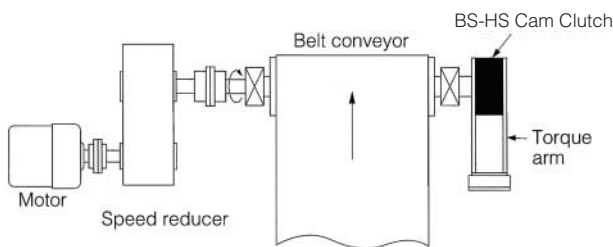

Note:

f = Friction coefficient of rollers
= 0.03 (normally used)

W = Weight of moving parts of the conveyor in the unloaded condition (kg/m)

Use the values from the table below.

Width of Belt (mm)	400	450	500	600	750	900
Estimated Weight: W	22.4	28	30	35.5	53	63
Width of Belt (mm)	1050	1200	1400	1600	1800	2000
Estimated Weight: W	80	90	112	125	150	160

V = Velocity of conveyor (m/min)

Q_t = Max. possible load (tonnes/hour)

h = Total lift (m)

ℓ = Horizontal distance between head pulley and tail pulley (m)

ℓ_0 = Modification coefficient for ℓ
= 49 m (normally used)

N = Shaft speed (r/min) on which the clutch is mounted.

SF = Service factor

Select service factor from table below:

SF	Service condition
1.5	Backstopping: Several times a day
2.0	Backstopping: More than several times a day

For Bucket Elevators

Selection Procedure:

$$(1) T = \frac{9.8 \times (L + D) \times Q_t \times D \times 1000}{120 \times V} \times SF \text{ (N·m)}$$

(2) Select the proper clutch which satisfies the calculated backstop torque (T).

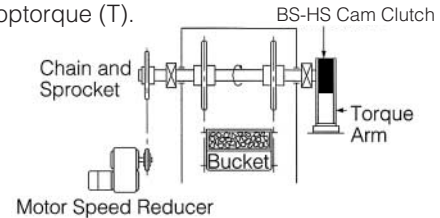

Note:

L = Total lift (m)

D = Pitch circle dia. of head sprocket (m)

Q_t = Possible maximum load (tons/hour)

V = Velocity of conveyor (m/min)

SF = Service factor

Use the values from the table below.

SF	Service condition
1.5	Several times a day
2.0	More than several times a day

Note:

For the conveyor types other than those in the above examples, calculate the backstop torque accordingly.

Always allow for the maximum possible load in your calculations, since backstopping often occurs when the conveyor is loaded above its normal loading capacity.

Motor Stall Torque Method

Another method commonly used to select the proper backstop clutch size for conveyors is to use the motor name plate ratings plus the motor's ability to produce excess torque. Depending on the motor size, it may develop over 300% of rated torque. After stalling an overloaded conveyor can overload the backstop. For proper selection of the backstop, all facets of the mechanical system should be considered to ensure that the backstop is not the weakest link in the conveyor drive. If the motor breakdown torque is not known, refer to the motor manufacturer.

Selection is based on the following formula:

$$\text{Motor stall torque } T = \frac{\text{Motor name plate kW} \times 9550}{\text{Shaft speed } N \text{ (r/min)}} \times \frac{S}{100} \leq T_{\max}$$

S = Stall torque percentage

T_{\max} = Cam Clutch maximum torque at the 500,000 times point of the fatigue capacity graph (N·m)

T_{\max} = Catalogue rated torque $\times 1.8$

or

$$\text{Motor stall torque } T = \frac{\text{Motor name plate kW} \times 9550}{\text{Shaft speed } N \text{ (r/min)}} \times SF \leq \text{catalogue max torque}$$

Depending on motor stall torque, apply the following service factors:

Stall torque	SF
Up to 180%	1.0
Up to 240%	1.3
Up to 300%	1.6

Select the Cam Clutch which satisfies the calculated torque T .

Lubrication and Maintenance

Lubricant (Grease-lubricated)

Grease is packed in the clutch before shipment.

Lubrication type : Emerlube M Manufactured by Kyodo Yushi Available from Tsubaki distributors

We are providing oil lubricated type. Please contact Tsubaki Emerson.

Maintenance

Change the grease and clean the inside of the Cam Clutch once every 6 months~12months.

See quantity of grease for each model on P4.

Note : Do not use grease that contains EP additives.

Life of Cam Clutches

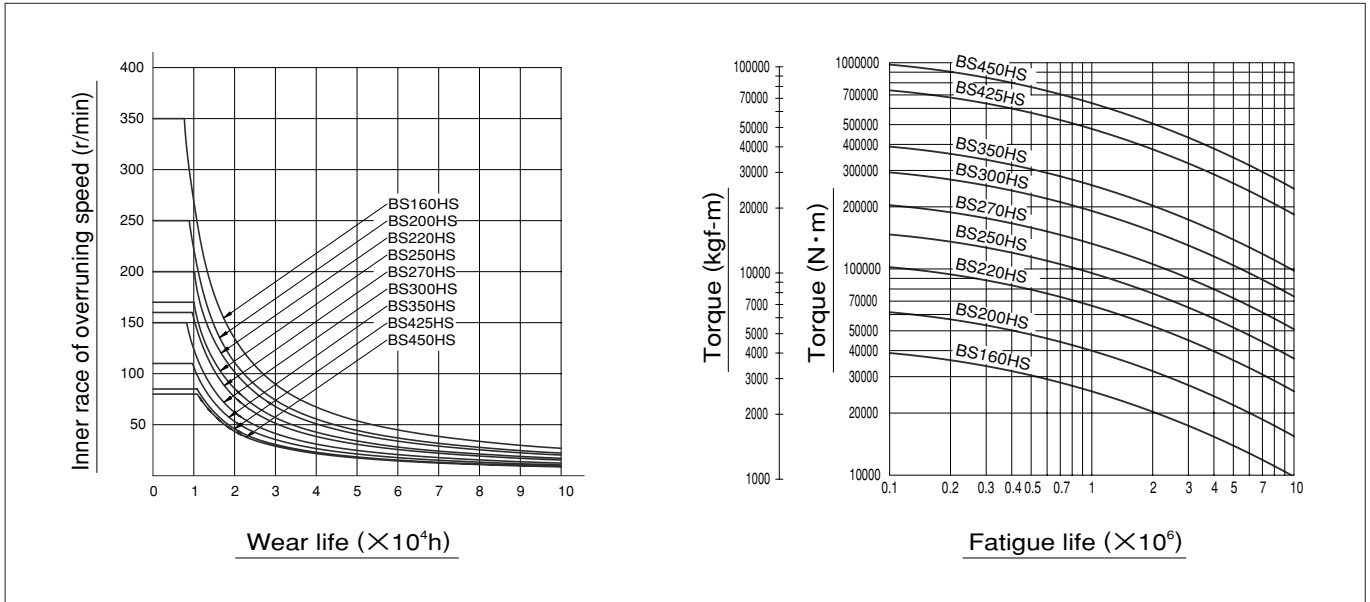

Special design versions available

Please contact Tsubaki Emerson in detail.

Double camcage model (BS160WHS~BS350WHS)

In BS425HS and BS450HS, double cam cage is standard specification.

MA model

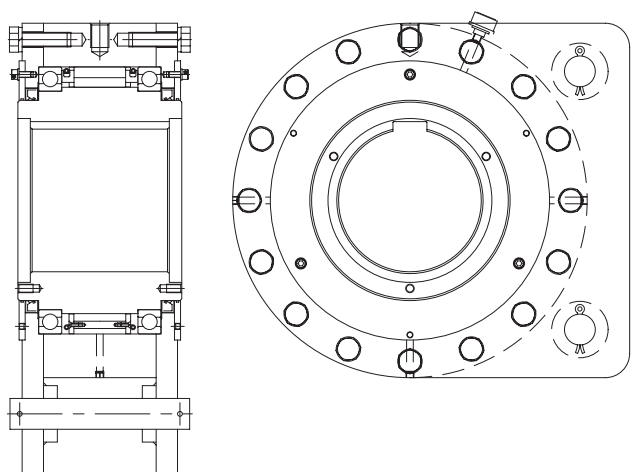
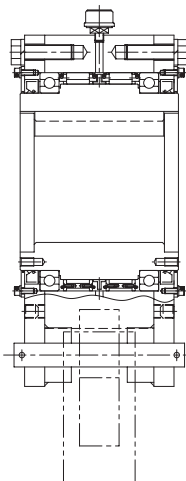



WARNING

USE CARE TO PREVENT INJURY.

COMPLY WITH THE FOLLOWING TO AVOID SERIOUS PERSONAL INJURY.

1. Guards must be provided on all power transmission and conveyor applications in accordance with provisions of ANSI/ASME B 15.1 1992 and ANSI/ASME B 20.1 1993 or other applicable standards. When revisions of these standards are published, the updated edition shall apply.
2. Always lock out power switch before installing, removing, lubricating or servicing a system that uses Cam Clutch products.
3. If the Cam Clutch is used for repeated starting and stopping, make sure the strength of the supports for the Cam Clutch are sufficient.
4. The capacity of your Cam Clutch may be effected by the accuracy of its set up, the amount of pressure exerted on it, wear on other parts in your system, or wear life of the Cam Clutch itself. Check the Cam Clutch at regular intervals and take any necessary safety precautions.
5. When connecting or disconnecting Cam Clutch products, eye protection is required. Wear safety glasses, protective clothing, gloves and safety shoes.



TSUBAKI EMERSON CO.

1-1, Kotari-Kuresumi, Nagaokakyo, Phone : (075) 957-3131
Kyoto 617-0833, Japan Facsimile : (075) 957-3122
Internet:
<http://www.tsubaki-emerson.co.jp/>

Group Companies:

U.S. TSUBAKI, INC.

301 E. Marquardt Drive
Wheeling, IL 60090
U.S.A.
Phone : 847-459-9500
Facsimile : 847-459-9515

TSUBAKI of CANADA LIMITED

1630 Drew Road
Mississauga, Ontario, L5S 1J6
Canada
Phone : 905-676-0400
Facsimile : 905-676-0904

TSUBAKI AUSTRALIA PTY. LTD.

Unit E. 95-101 Silverwater Road
Silverwater, N.S.W. 2128
Australia
Phone : 02-9648-5269
Facsimile : 02-9648-3115

TSUBAKIMOTO (THAILAND) CO., LTD.

No.1001, 10th Fl., The Offices at Centralworld
999/9 Rama I Rd., Pathumwan, Bangkok 10330,
Thailand
Phone : +66-2264-5354-6
Facsimile : +66-2251-3912

TSUBAKIMOTO SINGAPORE PTE. LTD.

25 Gul Lane
Jurong
Singapore 629419
Phone : 68610422/3/4
Facsimile : 68617035

TAIWAN TSUBAKIMOTO CO.

No. 7 Feng Sun Keng
Kuei Shan-Hsiang, Taoyuan-Hsien
Phone : 03-3293827/8/9
Facsimile : 03-3293065

TSUBAKI EMERSON MACHINERY (SHANGHAI) CO., LTD.

No. 4 leased factory building, No. 1588 Gaotai Rd.,
Shanghai Jiading Industrial Zone,
Shanghai
Phone : 021-6916-9305/6
Facsimile : 021-6916-9308

TSUBAKIMOTO EUROPE B.V.

Belder 1, 4704 RK Roosendaal
The Netherlands
Phone : 0165-594800
Facsimile : 0165-549450

TSUBAKIMOTO U.K. LTD.

Osier Drive, Sherwood Park
Annesley, Nottingham, NG15 ODX
United Kingdom
Phone : 01623-688788
Facsimile : 01623-688789

Distributed by: