

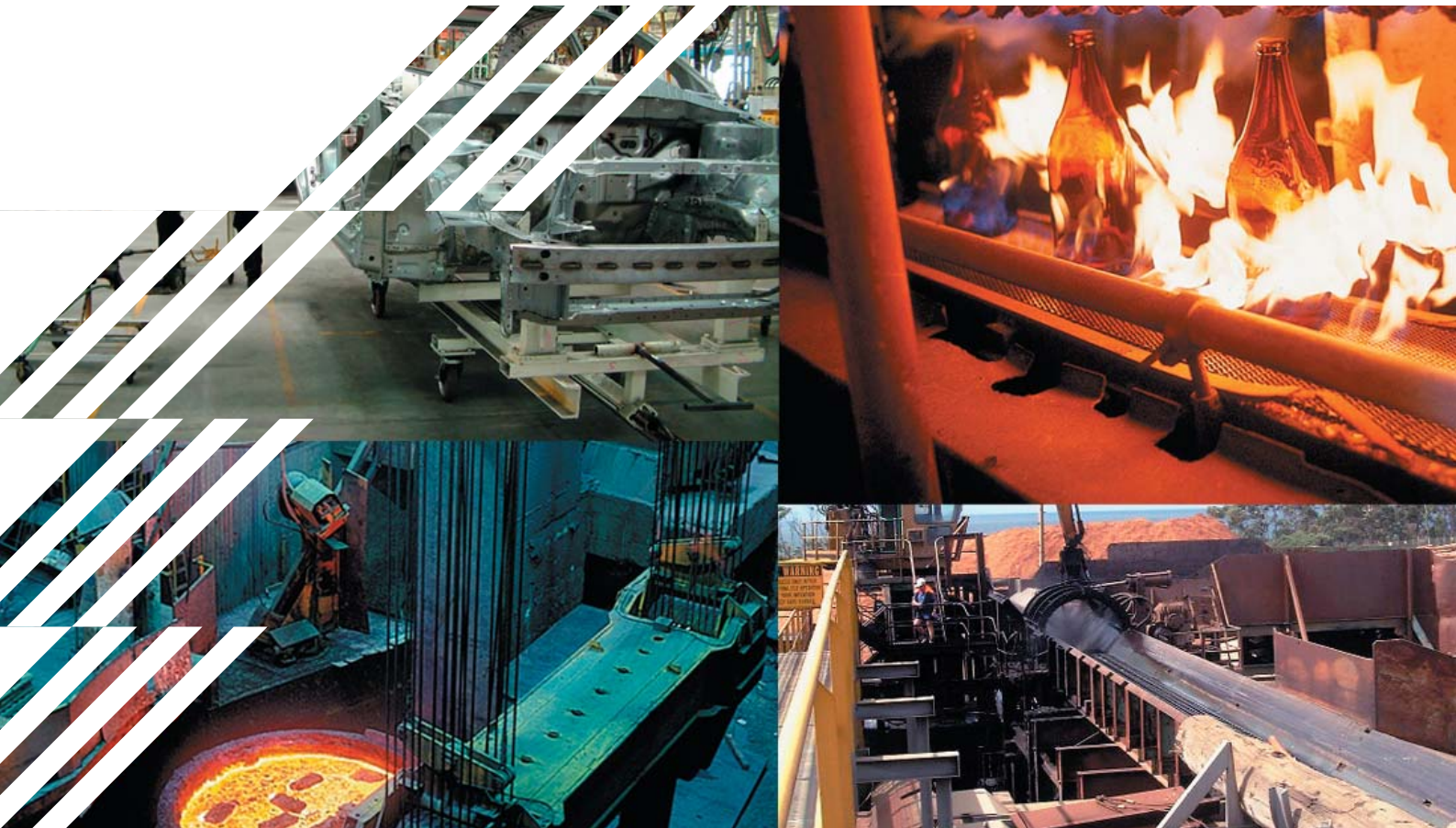

# British Standard Conveyor Chain



**“INNOVATION IN MOTION”**

# Table of Contents

• British Standard Conveyor Chain	4-5
• British Standard Solid Pin Conveyor Chain	6
• British Standard Hollow Pin Conveyor Chain	7
• British Standard Attachment Type	8
• British Standard Deep Side Plate Conveyor Chain	9
• British Standard Conveyor Sprockets	10
• Additional Services and Features	11
• Tsubaki Engineering Data	11
• British Standard Conveyor Chain Maintenance Check Points	12
• TSUBAKI Product Range	13

## British Standard Conveyor Chain

*“A new era in British Standard Conveyor Chain Performance”*

With the demands placed on industry today to compete at an international level, Engineers and Plant Managers are looking for maximum reliability in their equipment to increase productivity and performance.

Our focus at Tsubaki is to add value to our customers by capitalizing on our technical strengths in Power

Transmission and Materials Handling and to deliver the reliability and performance to met these demands.

We've travelled the globe to bring you an outstanding chain, which exceeds industry quality standards, for superior reliability and performance in your applications.



### Quality

- All parts are shot peened for greater fatigue strength and durability
- Statically Pre - Loaded to reduce initial wear
- Curved edge link plates for consistent tolerance control
- Pre- Lubricated during manufacturing and assembly with Fuchs™ Grease
- Tsubaki Specified Standards on Materials and Processing

All this backed by the knowledge of dealing with the Tsubaki guarantee of quality, performance and engineering expertise.

# Quality features built into the product, means real benefits for performance and reliability

5

“Our British Standard Conveyor Chain is manufactured to Tsubaki’s exacting specifications at a quality endorsed ISO globally certified facility also carrying the certification of the ‘API’ American Petroleum Institute Corporate Seal. This guarantee of quality to exceed the industry standard means a superior product throughout the entire process of design to manufacture.”

Shot Peened to All Components

Statically Pre - Loaded

Blanked Curved Edge Link Plates

Lubrication



Shot peened for greater fatigue strength and durability. Means a longer working life, less down time and higher performance.

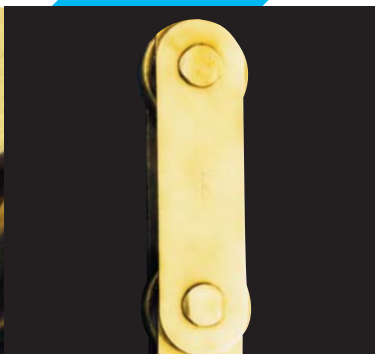

This process applies 1/3 of the rated breaking load to the chain ensuring component Alignment & Geometry Squareness which reduces initial wear and take up during the first stages of operation.

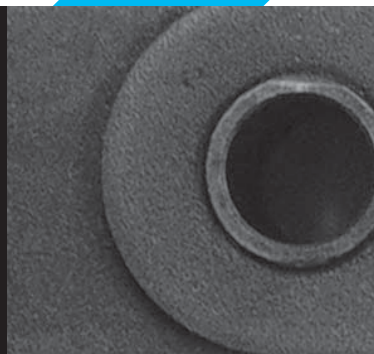

Blanked link plates for greater consistence in dimensional tolerances. Curved link plates prevent edges of links rising during engagement with the sprockets for ease of product transfer. Easier and safer handling for maintenance and installation.



FUCHS™ grease ISO 9001:2000 Certified with over 75 years of service to the industry.

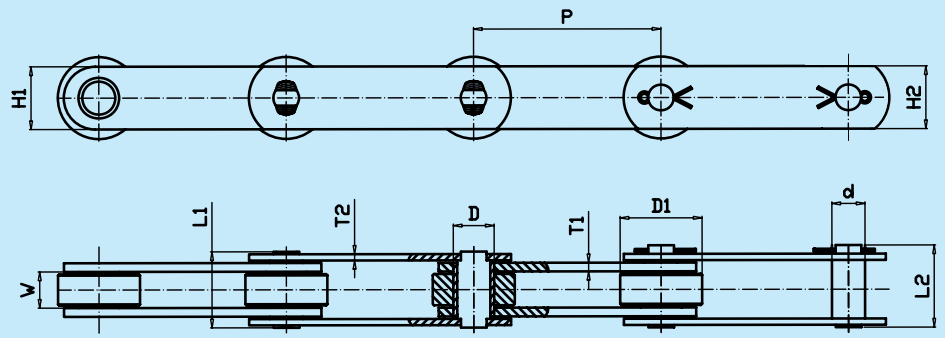
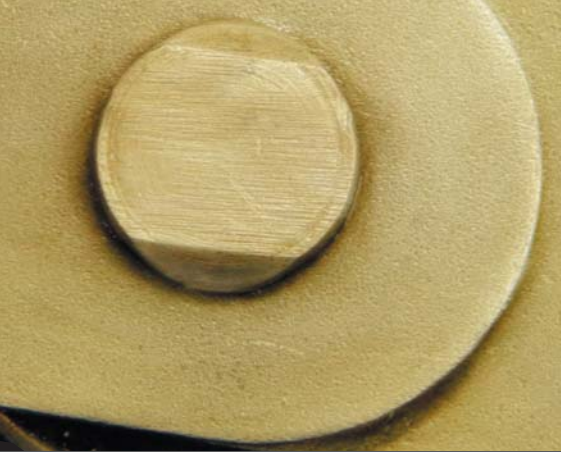

# British Standard Solid Pin Conveyor Chain

Minimum tensile strength in lbs	Pitch ('P')		Width between Inner Plates (Min) ('W')	Roller Dia ('D1')	Bush Dia ('D')	Solid pin Dia ('d')	Solid pin length (Max) ('L1')	Connecting pin length (Max) ('L2')	Inner Plate		Outer Plate		Avg. Wt/Mtr in (Kg)
	INCH	METRIC							Height ('H1')	Thickness ('T1')	Height ('H2')	Thickness ('T2')	
7500	2.0	50.80	15.00	31.80	18.00	14.00	38.00	42.60	25.40	3.80	25.40	3.80	4.07
	2.5	63.50											3.59
	3.0	76.20											3.29
	4.0	101.60											2.88
	5.0	127.00											2.65
	6.0	152.40											2.49
15000	2.0	50.80	19.00	47.60	23.60	19.00	46.00	49.80	38.10	5.10	38.10	3.80	8.14
	3.0	76.20											7.77
	4.0	101.60											6.56
	5.0	127.00											5.85
	6.0	152.40											5.34
	7.0	177.80											5.00
	8.0	203.20											4.78
9.0	228.60	4.53											
30000	4.0	101.60	25.40	66.67	33.20	26.90	60.00	65.40	51.00	7.10	51.00	5.10	14.50
	5.0	127.00											12.65
	6.0	152.40											11.40
	7.0	177.80											10.52
	8.0	203.20											9.87
	9.0	228.60											9.34
45000	5.0	127.00	38.10	88.90	38.10	31.80	82.00	88.20	61.00	8.90	61.00	7.60	24.69
	6.0	152.40											24.69
	7.0	177.80											22.31
	8.0	203.20											20.55
	9.0	228.60											19.21
60000	6.0	152.40	38.10	88.90	38.10	23.00	82.00	86.90	61.00	8.90	61.00	7.60	23.73
	7.0	177.80											21.96
	8.0	203.20											20.26
	9.0	228.60											18.94
90000	6.0	152.40	38.10	88.90	38.10	29.40	94.00	98.60	63.50	13.00	63.50	10.00	29.61
	9.0	228.60											23.78
	12.0	304.80											20.87

Welded attachments available upon request. Non Standard attachments available. All chains available in stainless steel and plated materials versions. \* Not Interchangeable With Other Brands\*

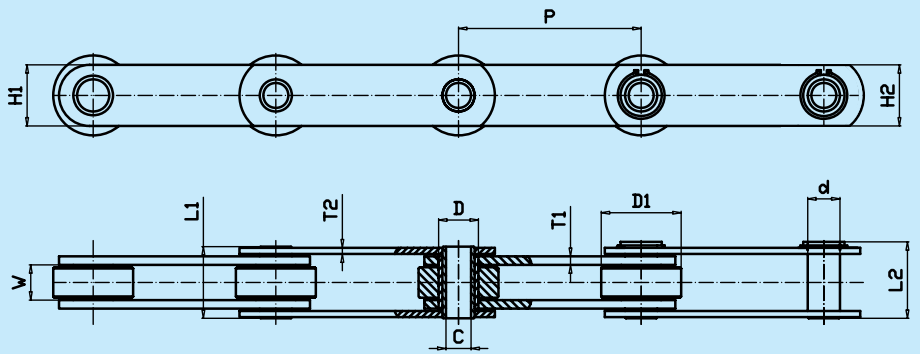

7

# British Standard Hollow Pin Conveyor Chain

Minimum tensile strength in lbs	Pitch ('P')		Width between Inner Plates (Min) ('W')	Roller Dia ('D1')	Bush Dia ('D')	Hollow pin bore Dia (Min) ('C')	Hollow pin Dia ('d')	Hollow pin length (Max) ('L1')	Connecting pin length (Max) ('L2')	Inner Plate		Outer Plate		Avg. Wt/Mtr in (Kg)
	INCH	METRIC								Height ('H1')	Thickness ('T1')	Height ('H2')	Thickness ('T2')	
6000	2.0	50.80	15.00	31.80	18.00	10.10	14.00	36.50	38.90	25.40	3.80	25.40	3.80	3.68
	2.5	63.50												3.29
	3.0	76.20												3.02
	4.0	101.60												2.71
	5.0	127.00												2.51
	6.0	152.40												2.38
12000	2.0	50.80	19.00	47.60	23.60	13.20	19.00	45.60	47.50	38.10	5.10	38.10	3.80	5.49
	3.0	76.20												7.28
	4.0	101.60												6.21
	5.0	127.00												5.57
	6.0	152.40												5.13
	7.0	177.80												4.83
	8.0	203.20												4.61
	9.0	228.60												4.42
24000	4.0	101.60	25.40	66.67	33.20	20.10	26.90	57.00	60.50	51.00	7.10	51.00	5.10	13.16
	5.0	127.00												11.58
	6.0	152.40												11.27
	7.0	177.80												9.77
	8.0	203.20												9.21
	9.0	228.60												8.78
	12.0	304.80												7.90
36000	5.0	127.00	38.10	88.90	38.10	23.10	31.80	79.50	84.00	61.00	8.90	61.00	7.60	25.47
	6.0	152.40												22.62
	7.0	177.80												20.58
	8.0	203.20												19.05
	9.0	228.60												17.87
	12.0	304.80												15.49

Welded attachments available upon request. Non Standard attachments available. All chains available in stainless steel and plated materials versions. \* Not Interchangeable With Other Brands\*

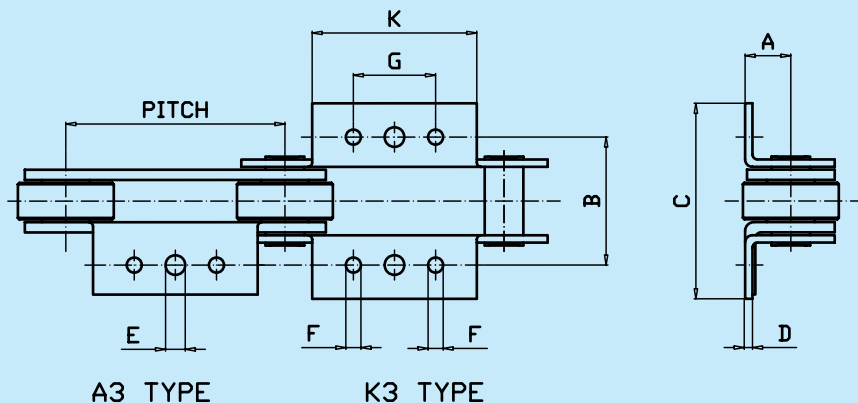
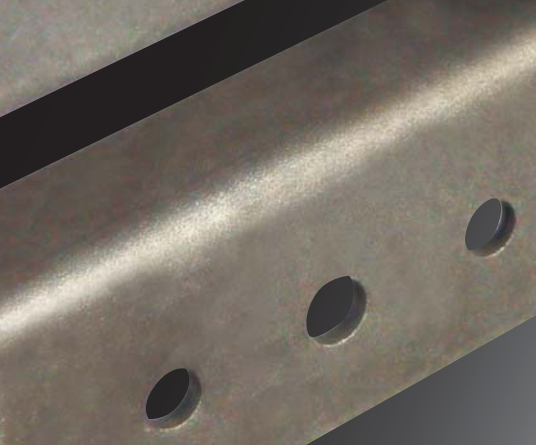

# British Standard Attachment Type

Minimum tensile strength in lbs	Pitch ('P')		Attachment Type Inner/Outer ('A3 & K3')	Platform Height (MM) ('A')	Transverse Pitch (MM) ('B')	Width Overall Attach Plate Inner/Outer (MM) ('C')	Attachment Thickness Inner/Outer (MM) ('D')	Centre Hole Dia (MM) ('E')	Outer Hole Dia (MM) ('F')	Hole Pitch (MM) ('G')	Platform Length (MM) ('K')
	INCH	METRIC									
6000 / 7500	3.0	76.20	A3 & K3	19.00	76.20	106 / 115	3.8	10.50	9.20	22.20	43.00
	4.0	101.60	A3 & K3	19.00	76.20	106 / 115	3.8	10.50	9.20	31.80	64.00
	6.0	152.40	A3 & K3	19.00	76.20	106 / 115	3.8	10.50	9.20	57.20	114.00
12000 / 15000	3.0	76.20	A3 & K3	31.80	89.00	130 / 136	5.1 / 3.8	13.70	10.50	31.80	63.50
	4.0	101.60	A3 & K3	31.80	89.00	130 / 136	5.1 / 3.8	13.70	10.50	31.80	63.50
	6.0	152.40	A3 & K3	31.80	89.00	130 / 136	5.1 / 3.8	13.70	10.50	57.20	114.50
24000 / 30000	6.0	152.40	A3 & K3	38.00	108.00	146 / 157	7.1 / 5.7	15.30	12.20	57.20	107.00

Note: For 2" pitch conveyor chain attachment styles A1, K1, A2 and K2 will be provided.

Welded attachments available upon request. Non Standard attachments available. All chains available in stainless steel and plated materials versions. \* Not Interchangeable With Other Brands\*

*A3 and K3 standard stock design. Intergrated one piece design for strength and integrity. SA, SK and G style attachments available. Special Welded attachments available.*

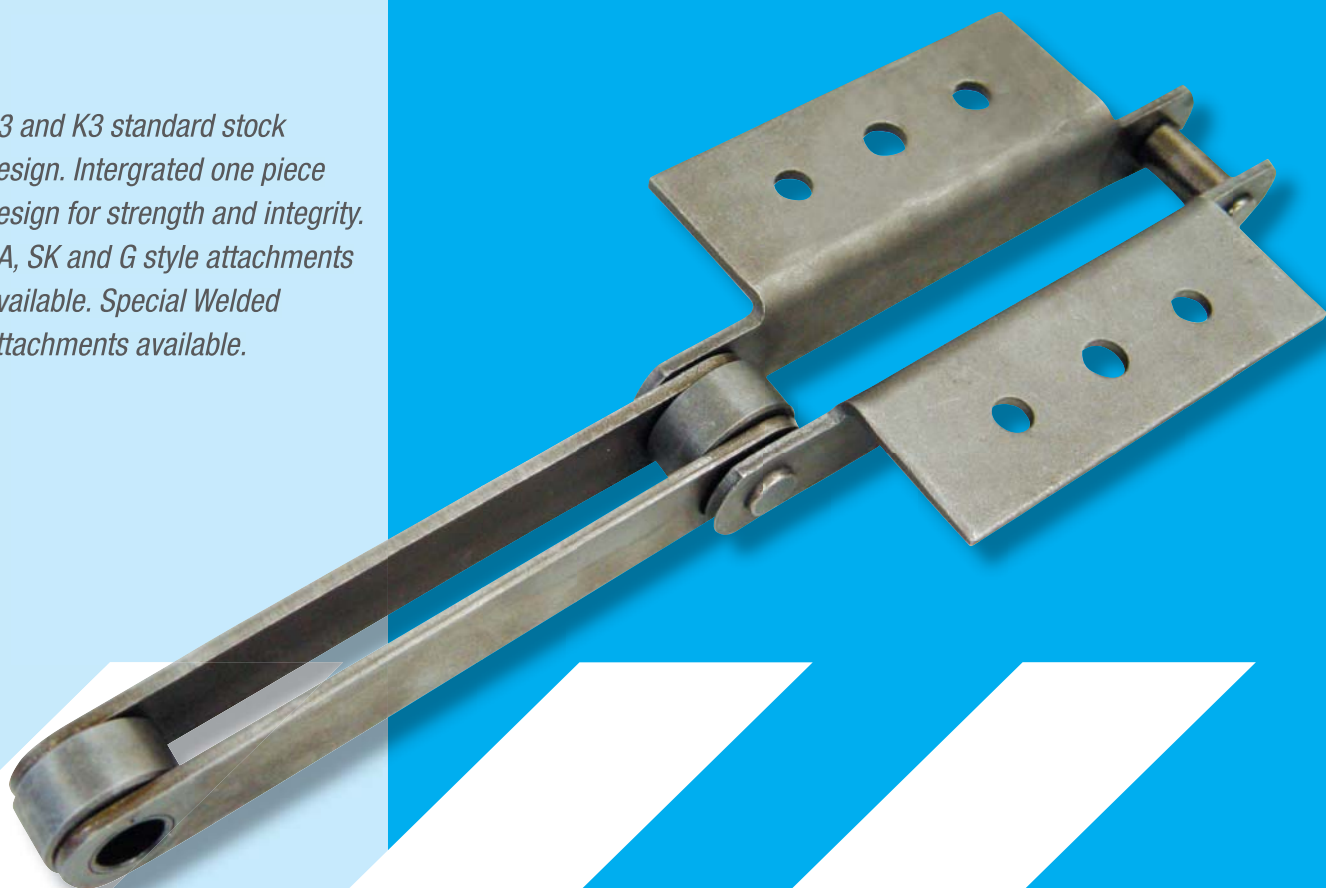

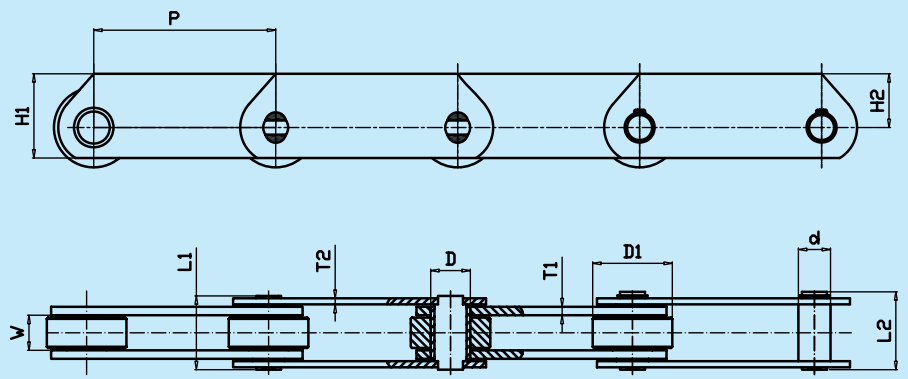

9

# British Standard Deep Side Plate Conveyor Chain

Minimum tensile strength in lbs	Pitch ('P')		Width between Inner Plates (Min) ('W')	Roller Dia ('D1')	Bush Dia ('D')	Solid pin Dia ('d')	Solid pin length (Max) ('L1')	Connecting pin length (Max) ('L2')	Inner Plate		Outer Plate		Avg. Wt/Mtr in (Kg)
	INCH	METRIC							Height ('H1')	Thickness ('T1')	Height ('H2')	Thickness ('T2')	
7500	2.0	50.80	15.00	31.80	18.00	14.00	38.00	42.60	38.70	3.80	26.00	3.80	4.97
	2.5	63.50											4.46
	3.0	76.20											4.14
	4.0	101.60											3.71
	5.0	127.00											3.45
	6.0	152.40											3.29
15000	2.0	50.80	19.00	47.60	23.60	19.00	46.00	49.80	51.05	5.10	32.00	3.80	7.31
	3.0	76.20											8.59
	4.0	101.60											7.37
	5.0	127.00											6.64
	6.0	152.40											6.15
	7.0	177.80											5.80
	8.0	203.20											5.54
9.0	228.60	5.33											
30000	4.0	101.60	25.40	66.67	33.20	26.90	60.00	65.40	70.50	7.10	45.00	5.10	16.34
	5.0	127.00											14.45
	6.0	152.40											13.18
	7.0	177.80											12.27
	8.0	203.20											11.60
	9.0	228.60											11.08
45000	5.0	127.00	38.10	88.90	38.10	31.80	82.00	88.20	75.50	8.90	45.00	7.60	AOR
	6.0	152.40											AOR
	7.0	177.80											AOR
	8.0	203.20											AOR
	9.0	228.60											AOR
	12.0	304.80											AOR

Welded attachments available upon request. Non Standard attachments available. All chains available in stainless steel and plated materials versions. \* Not Interchangeable With Other Brands\*

## British Standard Conveyor Sprockets

*Leading Drive Performance relies on the whole system not just various components of the drive system.*

*The Chain and Sprockets work as one, this is why Tsubaki not only delivers a superior chain, but bring to the market the best in sprocket performance.*

*With our capabilities to design and select the right sprocket for your application, Tsubaki makes the right choice easy.*

**“Performance, Precision a Total Drive Solution”**



- Reduced downtime for maintenance
- Lower replacement costs
- Increased productivity
- Increased chain life performance
- Increased profits

**TYPE A: Plain Bore (No hub extension)**

**TYPE B: Plain Bore (One side hub extension)**

**TYPE C: Plain Bore (Two side hub extension)**

**TYPE D: Plain Bore (Split hub option)**

All sprockets are made to order and finished in the bore and keyway size of your application.  
(Taper Lock assemblies are available)



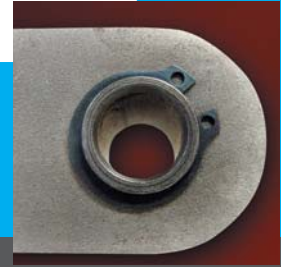

## Additional Services and Features

### Additional Service

Qualified Engineering Support  
Infield Service Support  
Infield Technical Support

### Special Chain Features

Bolted Connecting Links  
Circlip Hollow Pin Connectors  
Rivet Connecting Links

### Special Materials and Coatings

Stainless Steel  
Zinc Plated  
Galvanized Plated  
Nickel Plated  
MolyBonded™ Coated  
ZAC - Coated

## Tsubaki Engineering Data

Careful and accurate installation of both the chain and sprockets is required for a smooth operating conveyor chain/s to ensure maximum life of the system.

1. Adjust shafts with a level. The inclination should be 1/300
2. Align the drive shaft and the driven shaft in parallel. The parallelism should be within 1 mm
3. Align the axial alignment of the two sprockets (drive and driven) within the tolerance below  
Shaft distance up to 1m: 1mm  
1m to 10m: (distance between two shafts)/1,000 (mm)  
Over 10m 10mm
4. Fix the sprockets to the shaft using keys, collars, set bolts etc.

# British Standard Conveyor Chain Maintenance Check Points

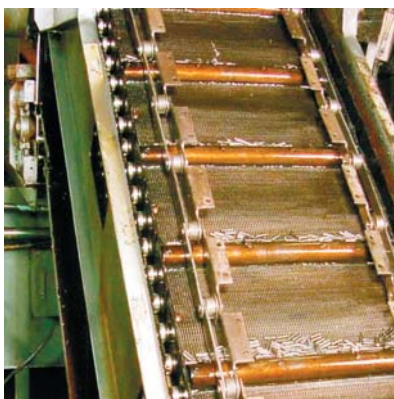

Check Points	Comments
<b>Centreing</b>	A high precision guide rail is essential to ensure proper centreing of the conveyor. If centreing is not accurate (with no side rail), the conveyor chain will wobble and weave resulting in shorter conveyor chain life.
<b>Sprocket Alignment</b>	When two or more sprockets are installed in a row, be sure to align the position of the sprocket teeth. If the sprocket teeth are not properly aligned, the working load will not be equally divided and will cause the chain to twist.
<b>Take up</b>	If take-ups on both sides are uneven, the conveyor chain will not engage smoothly with the sprocket/s.
<b>Initial Chain Tension</b>	Maintain adequate chain slack. If chain tension is too high, loss of power will occur. This is a dangerous situation. If too loose, the chain will climb the sprocket/s.
<b>Trial Run / Commissioning</b>	Trial run after installation should be made under no load conditions by switching On & Off several times intermittently. After inspection, continuous operation may begin.
<b>Stopping Conveyor</b>	Stop conveyor under no load conditions, or remaining material will impose and overload when the conveyor starts again.
<b>Lubrication</b>	Lubricate conveyor chain periodically, except conveyor chain like Flow Conveyor which runs without lubrication. Lubrication of reducer, bearings and driving roller chain is essential.
<b>Securing Conveyor Parts</b>	Parts fastened to the conveyor such as buckets, aprons, slats, etc, are apt to loosen due to vibration. Pay careful attention to fastening nuts and bolts and check tension periodically.
<b>Amounts of Chain Slack</b>	Regularly check and adjust the amount of chain slack.
<b>Temperature and Prevention of Freezing</b>	When differences in temperatures (summer and winter or between day and night in the winter) are very severe, conveyor damage may occur. Under these circumstances, operate the conveyor carefully taking any variations in temperature into account.
<b>Conveyor Record of Use and Maintenance</b>	After installing the conveyor, prepare a record of the expected capacity to be conveyed, conveyor speed, r.p.m of main shaft, electric current, voltage, working hours, actual conveying capacity, inspection date, lubricating date, details of trouble etc. This will serve as protection against unexpected accidents. This record will also be convenient for maintenance and repairs.

## TSUBAKI Product Range



### Roller Chain Products:

- Metric Conveyor Chain
- ANSI Roller Chain
- BS Roller Chain
- Double Pitch Conveyor Chain
- Attachment Chains
- Plastic Chains
- Corrosion Resistance Chains
- Bearing Roller Chain
- Bearing Bush Chain
- Fork Lift Leaf Chain
- Super Series Chains
- HT Chains
- RO Heavy Drive Chains

### Power Transmission Products:

- BS Cam Clutches
- MG Cam Clutches
- Torque Limiter Devices
- Electronic Shear Pins
- Sprockets ANSI & BS
- Hypoid Gear Motor
- Power Cylinders
- Couplings
- Cableveyor
- Power Locks
- Shaft Mounts
- Miter Boxes
- Gear Motors



## WARNING

USE CARE TO PREVENT INJURY COMPLY WITH THE FOLLOWING TO AVOID SERIOUS PERSONAL INJURY

1. GUARDS MUST BE PROVIDED ON ALL POWER TRANSMISSION AND CONVEYOR APPLICATIONS IN ACCORDANCE WITH PROVISIONS OF ANSI/ASME B 15.1 1992 "SAFETY STANDARDS FOR MECHANICAL POWER TRANSMISSION APPARATUS" AND ANSI/ASME B 20.1-1990 SAFETY STANDARDS FOR CONVEYORS AND RELATED EQUIPMENT", OR OTHER APPLICABLE STANDARDS. WHEN REVISIONS OF THESE STANDARDS ARE PUBLISHED, THE UPDATED EDITION SHALL APPLY
2. DISCONNECT POWER. ALWAYS LOCK OUT POWER SWITCH BEFORE INSTALLING, REMOVING, OR SERVICING UNIT OR LUBRICATING CHAIN. COMPLY WITH OCCUPATIONAL HEALTH AND SAFETY STANDARDS 1910.147 "THE CONTROL OF HAZARDOUS ENERGY (LOCK OUT/TAG OUT)".
3. WHEN CONNECTING OR DISCONNECTING CHAIN:
  - \*. EYE PROTECTION IS REQUIRED. WEAR SAFETY GLASSES, PROTECTIVE CLOTHING GLOVES AND SAFETY SHOES
  - \*. SUPPORT THE CHAIN TO PREVENT UNCONTROLLED MOVEMENT OF CHAIN AND PARTS
  - \*. USE OF PRESSING EQUIPMENT IS RECOMMENDED. TOOLS MUST BE IN GOOD CONDITION AND PROPERLY USED.
  - \*. DETERMINE CORRECT DIRECTION FOR PIN/RIVET REMOVAL OR INSERTION.
4. ALWAYS TEST RUN EQUIPMENT AND COMMISSION PRIOR TO OPERATION.



# **TSUBAKI**

**TSUBAKI Australia Pty Ltd. Web Address: [www.tsubaki.com.au](http://www.tsubaki.com.au) Email Address: [sales@tsubaki.com.au](mailto:sales@tsubaki.com.au)**

### **Sydney**

Unit E, 95 – 101 Silverwater Rd  
Silverwater, NSW 2128  
Ph + [61] (0) 2 9648 5269  
Fax + [61] (0) 2 9648 3115

### **Brisbane**

Unit 1, 14 Overlord Place  
Acacia Ridge, QLD 4110  
Ph + [61] (0) 7 3273 6033  
Fax + [61] (0) 7 3273 6868

### **Melbourne**

34 Glenvale Crescent  
Mulgrave, VIC 3170  
Ph + [61] (0) 3 9562 5898  
Fax + [61] (0) 3 9562 5707

### **Perth**

110 Radium Street  
Welshpool, WA 6106  
Ph + [61] (0) 8 9356 9700  
Fax + [61] (0) 8 9356 9800

